

www.toolarms.com



OWNER'S MANUAL

This manual contains:



IMPORTANT SAFETY INFORMATION

INSTALLATION INSTRUCTIONS

MAINTENANCE

FACTORY SERVICE

REPAIR PARTS

WARRANTY

Models covered:

PA806

PA815

PA806-OM

PA815-OM



Ergonomic Tool Arms, LLC

PO Box 534

Doylestown, PA 18901

e-mail; etainfo@toolarms.com

855-TOOL ARM (855-866-5276)

FAX 484-493-1536

www.toolarms.com



WARNING

**READ THIS MANUAL CAREFULLY PRIOR TO
INSTALLATION AND OPERATION OF THIS TOOL ARM!**

FAILURE TO UNDERSTAND AND OBSERVE THE FOLLOWING WARNINGS COULD RESULT IN INJURY.



HEARING PROTECTION may be required depending on the noise level of the power tool used with this tool arm or the surrounding work environment.



Always wear EYE PROTECTION when installing, operating or performing maintenance on this tool arm and the power tool used on it.



Use CAUTION – PINCH POINTS exist during installation, use and maintenance of this tool arm.



Operate at assembly tool manufacturer's maximum operating pressure or 125 psi (8.6 bar), whichever is lower. Never operate at higher than maximum pressure.



Do not carry arm by air hose or manipulate arm using the air hose as a handle. Replace damaged or deteriorated air hoses and fittings immediately.



Disconnect air supply and lower tool arm to lowest position before changing driver bits, tool inserts or cutters, etc.



Become familiar with torque and weight limits for your specific tool arm model and do not exceed these limits (see label on Forearm or following pages of this manual) .



Do not remove any labels – replace any worn or damaged labels that list maximum specifications.



ETA is not responsible for customer modification of this tool arm and resultant safety concerns.



It is the responsibility of the employer to place the information in this manual in the hands of the operator and to make sure they understand how to safely operate this tool arm and any components added to it.

INSTALLATION INSTRUCTIONS

- 1) Remove contents from shipping cartons and inspect for damage.
- 2) Determine base location. See Mounting Ideas and Spec Sheets on website to determine the best location.
- 3) Place Base and Post where you want to mount it and mark hole locations.
- 4) Drill thru holes in work bench or other ridged surface if possible. Otherwise anchor securely using appropriate lag bolts, concrete anchors, ect. For thru holes use 3/8" bolts, grade 5 or higher. Be sure any anchors used have sufficient length to secure the base safely. The pipe/post can be removed for convenience while mounting base is being installed. Leave bolts or anchors hand tight temporarily.
- 5) Reinstall post (if removed or if additional pipe components are used) *Note; If 1-1/4 npt elbows and tees are used, make provision to either pin, set screw or tack weld joints together to keep them from loosening. Wait until arm is positioned satisfactorily before doing this. One-piece vertical pipes do not need additional fastening.*
- 6) Screw tool arm onto post and hand tighten Base Cap snugly.
- 7) *This step is easier if 2 people are involved.* Rotate arm slowly and see if it swings on its own once you let go of it. Using the set screws in the base plate, adjust or level the arm until it stays wherever you position it. Whenever you need to raise the base using the set screw, loosen mounting bolts on either side of that set screw slightly as you turn set screw in. Repeat this process until arm stays wherever you place it. Tighten the 3 bolts securely and recheck level. *It is not necessary to use a level to accomplish this task; you can level the base strictly by observing tool arm behavior.*
- 8) Tool arm pivot joints are preset during manufacture to pivot freely for ease of movement about the work zone. If it is desirable in your application that the tool arm not articulate as freely, then a slight drag can be added to the 2 horizontal pivot points by tightening the 1/2" nylon locknut on the rear pivot and the 3/8" nylon locknut on the center pivot. You will need a 3/4" and 9/16" wrench respectively. Care should be taken to tighten these in increments of a few degrees and no more than necessary, as accelerated wear to bearings will result if over tightened. Do not adjust these pivot points unless it is necessary for your application.
- 9) Mount your assembly tool on the front of the arm. Use thread sealant for air connections. When mounting tool onto arm via air inlet or into one of our tool holder be mindful of start lever and reverse button, handle position etc. to make the tool position as ergonomic as possible. If you are mounting driver in a UVTH, Universal Vertical Tool Holder, do not over

tighten so as to damage your tool. You can always tighten further if the tool spins in the holder during initial testing. Caution should be taken to clamp tool in an appropriate part of the tool body that can withstand the clamping force. Consult the tool manufacturer for more info on where to clamp the tool. If appropriate clamping force is not sufficient to keep the tool from spinning, then a thin sheet of adhesive backed rubber can be purchased elsewhere and the clamp jaws can be lined with it to increase friction to avoid over clamping thin walled tool bodies. Most industrial tools however, have an area near the spindle end of the tool where the clamping pressure can be supplied sufficiently to withstand the tool's torque.

- 10) Supply a flexible air hose to the 3/8 npt female inlet in the rear block of the tool arm. Use 3/8" ID hose minimum and no more than 1 quick connect coupling in the supply line to the tool arm. Air supply should be dry and filtered just before it is fed to the arm air inlet and lubricated only if required by power tool manufacturer. The ETA arm requires no air line lubrication for its components. Be sure to allow enough slack in the supply hose so you do not inhibit arm movement. **Installation of a Lock-out/Tag-out Valve in the air line supplying the tap arm is required in most circumstances. Consult those responsible for work safety in your organization regarding the necessity for a Lock-out/Tag-out Valve.** If air tool lubrication is required, use only high quality air tool lubricants. Do not use general purpose oils in any air system. This will void the warranty and deteriorate the seal components.
- 11) Turn air supply on and check your connections for air leaks.
- 12) Adjust the small air regulator supplying the float cylinder until the arm, tool and driver bit are balanced and easily float with little resistance. Tool arm should now be ready to work for you.

TOOL ARM MAINTENANCE & FACTORY SERVICE

Unless problems arise due to worn parts or weakened or compromised pneumatic hoses or seals, there is no maintenance required on Ergonomic Tool Arms. Inspect for worn or compromised parts periodically and repair as necessary. See warranty for maintenance issues within the first 1 to 3 years.

Repair parts can be purchased from ETA through your Industrial Distributor or ETA will perform repairs at our location at a nominal cost, based on a written estimate after inspection of returned product. An RMA # is required to return product to ETA.

MODEL #	TYPE of TOOL	TYPICAL USES	MAX VERTICAL TORQUE		MAX HORZ. TORQUE *		MAX TOOL WEIGHT ^		TOOL HOLDER OPTIONS AVAILABLE	TOOL HOSE ID
			in-lbs	Nm	in-lbs	Nm	Lbs	kg		
PA806	in-line pneumatic	vertical fasteners	800	90	400	45	6	2.7	yes	3/8"
PA815	in-line pneumatic	vertical fasteners	800	90	400	45	15	6.8	yes	3/8"

© 2010, Ergonomic Tool Arms, LLC

MOUNTING IDEAS

All ETA Tool Arms use 1/4" NPT pipe for the Base Post. Use standard Schedule 40 iron or galvanized pipe for elbows, tees & pipe – available at home centers and hardware stores. To avoid movement, elbows and tees should be tack welded or drilled and pinned following final positioning. Vertical lengths of pipe used with ETA Base & ETA Post Cap do not need to be tacked or pinned.

© 2010, Ergonomic Tool Arms, LLC

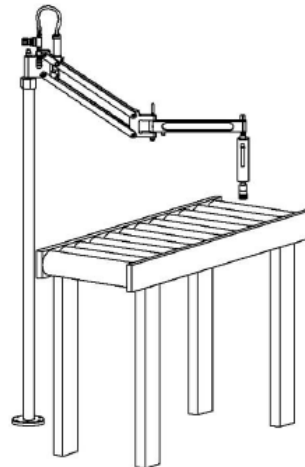
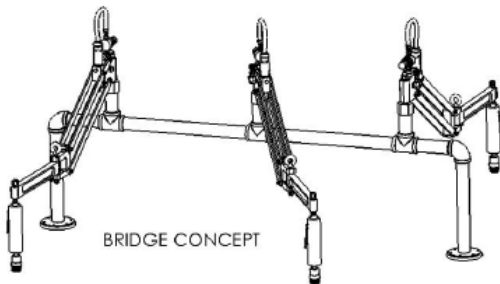
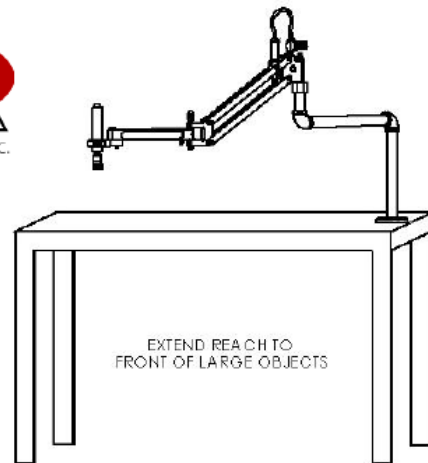
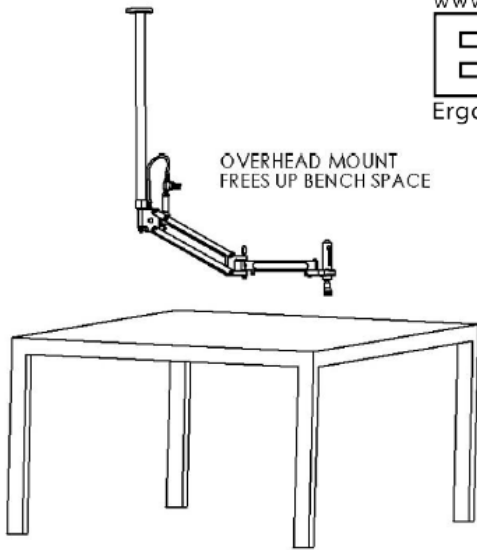
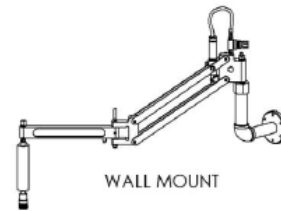
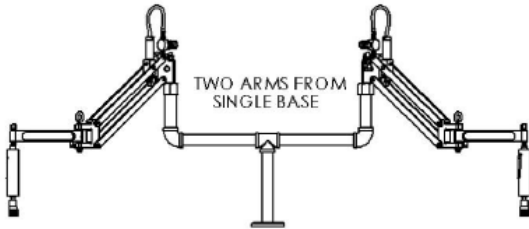

TOOL ARM MOUNTED ON FLOOR BEHIND CONVEYOR BELT OR BENCH

© 2010, Ergonomic Tool Arms, LLC

Model PA806 & PA815 Replacement Parts

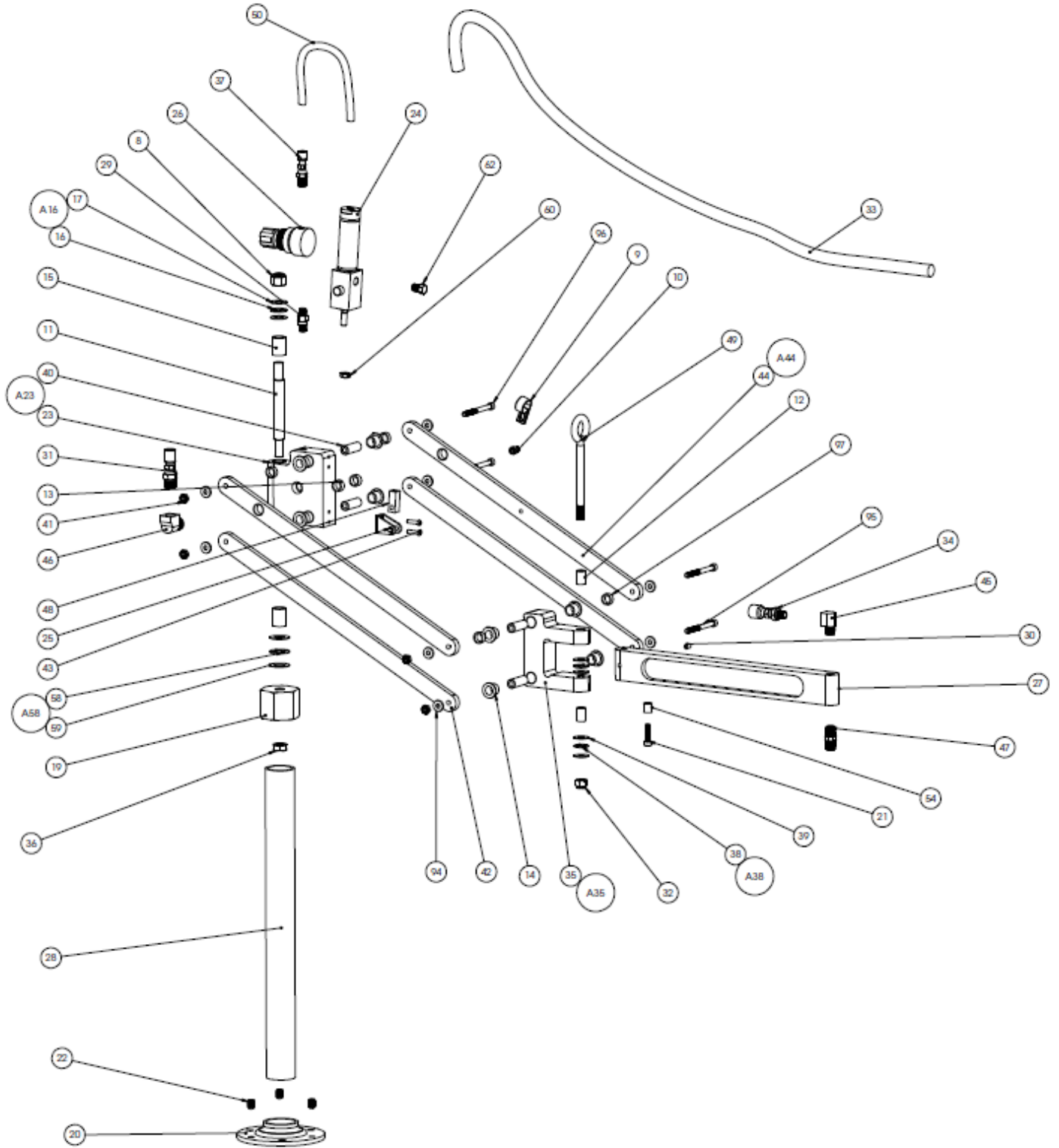

Parts Lists for PA806 & PA815 are on the next 2 pages.

PA806 Replacement Parts

ITEM NO.	ETA PART #	DESCRIPTION	QTY	ITEM NO.	ETA PART #	DESCRIPTION	QTY
8	33500-108-0	Rear Pivot Lock Nut	1	60	33500-160-1	Rod Eye Jam Nut	1
9	33500-109-0	Hose Loop	1	62	38400-162-0	1/8" Breather Vent	1
10	33500-110-0	Hose Loop Screw	1	94	33500-194-0	Washers	8
				95	33500-195-0	Medium Arm Pivot bolts	4
A16*	A116TB	Thrust Bearing Assembly - Top Rear	1				
		* Includes the following ITEM NOs					
16		Thrust Bearing (available in A16 only)	1				
17		Thrust Washer (available in A16 only)	2				
19	36200-119-0	Post Cap	1				
20	36200-120-0	Base	1				
21	33500-121-0	Jack-knife Bolt	1				
22	33500-122-0	3/8 Base Level Screws	3				
A23*	A123RB-5	Rear Block Assembly	1				
		* Includes the following ITEM NOs					
11		Base Pivot Pin (available only in A23)	1				
14		Arm Pivot Pin Bushings (avail. only in A23 or A35)	4				
15		Rear Block Bushings (avail. Only in A23)	2				
23		Rear Block (available only in A23)	1				
40		Pivot Pin (avail. only in A23 or A35)	2				
24	38400-124-0	Air Cylinder	1				
25	38400-125-0	Rod Clevis Bracket & Pin	1				
26	38400-126-0	Pressure Regulator	1				
27	36200-127-0	Forearm	1				
28	N/A	1-1/4" Iron Pipe (purchase locally)	1				
29	38400-129-0	Check Valve	1				
30	33500-130-0	Eye Bolt Set Screw	2				
31	38400-131-0	Fitting 3/8 npt to 5/16 Braided Hose	1				
32	33500-132-0	Center Pivot Lock Nut	1				
33	38400-133-0	5/16" ID Braided Hose x 38" [NOT PICTURED]	1				
34	38400-134-0	Fitting 1/4 npt to 5/16 Braided Hose	1				
A35*	A135CB-5	Center Block Assembly	1				
		* Includes the following ITEM NOs					
12		Center Block Bushings (available only in A35)	2				
14		Arm Pivot Pin Bushings (avail. only in A23 or A35)	4				
35		Center Block (available only in A35)	1				
40		Pivot Pin (avail. only in A23 or A35)	2				
49		Precision Eye Bolt (available only in A35)	1				
36	33500-136-0	Base Pivot Pin Jam Nut	1				
37	38400-137-0	Fitting - 1/8 npt to 1/4 Tube	1				
A38*	A138TB-SET	Thrust Bearing Assembly - Center -Pair	1				
		* Includes the following ITEM NOs					
38		Thrust Bearings	2				
39		Thrust Washers	4				
41	33500-141-0	Arm Pivot Nuts	4				
42	46200-142-0	Heavy Duty Lower Parallel Arm	2				
43	33500-143-0	Clevis Bracket Mtg Screws	2				
A44*	A144UA-8	Upper Parallel Arm Assembly	1				
		* Includes the following ITEM NOs					
13		Upper Arm Cyl. Bushings (available in A44 only)	2				
44		H D Upper Parallel Arm (available in A44 only)	2				
45	38400-145-0	Fitting - 1/4 npt short street elbow	1				
46	38400-146-0	Fitting - 3/8 npt street elbow	1				
47	38400-147-0	Hardened 1/4 npt Hex Nipple	1				
48	36200-148-0	Rod Eye	1				
50	38400-150-0	1/4" OD polyurethane tube -Red 8" long	1				
54	43500-154-0	Large Jack-knife Stop	1				
A58*	A158TB	Thrust Bearing Assembly - Bottom Rear	1				
		* Includes the following ITEM NOs					
58		thrust bearing (available in A58 only)	1				
59		thrust washers (available in A58 only)	2				

For PA806-OM

	Substitute		
A23	A123RB-5-OM	Rear Block Assembly- Overhead Mount	1
	For		
A23	A123RB-5	Rear Block Assembly	

PA815 Replacement Parts

ITEM NO.	ETA PART #	DESCRIPTION	QTY	ITEM NO.	ETA PART #	DESCRIPTION	QTY
8	33500-108-0	Rear Pivot Lock Nut	1	60	43500-160-1	Rod Eye Jam Nut	1
9	33500-109-0	Hose Loop	1	62	48400-162-0	1/4" Breather Vent	1
10	33500-110-0	Hose Loop Screw	1	94	33500-194-0	Washers	8
				95	33500-195-0	Medium Arm Pivot bolts	2
A16*	A116TB	Thrust Bearing Assembly - Top Rear	1	96	33500-196-0	Long Arm Pivot bolts	2
		* Includes the following ITEM NOs		97	33500-197-0	Spacer	4
16		Thrust Bearing (available in A16 only)	1				
17		Thrust Washer (available in A16 only)	2				
19	36200-119-0	Post Cap	1				
20	36200-120-0	Base	1				
21	33500-121-0	Jack-knife Bolt	1				
22	33500-122-0	3/8 Base Level Screws	3				
A23*	A123RB-8	Rear Block Assembly	1				
		* Includes the following ITEM NOs					
11		Base Pivot Pin (available only in A23)	1				
14		Arm Pivot Pin Bushings (avail. only in A23 or A35)	4				
15		Rear Block Bushings (avail. Only in A23)	2				
23		Rear Block (available only in A23)	1				
40		Pivot Pin (avail. only in A23 or A35)	1				
40		Long Pivot Pin (avail. only in A23 or A35)	1				
24	48400-124-0	Large Air Cylinder	1				
25	38400-125-0	Rod Clevis Bracket & Pin	1				
26	48400-126-0	Prec. Pressure Regulator	1				
27	36200-127-0	Forearm	1				
28	N/A	1-1/4" Iron Pipe (purchase locally)	1				
29	38400-129-0	Check Valve	1				
30	33500-130-0	Eye Bolt Set Screw	2				
31	48400-131-0	Fitting 3/8 npt to 3/8 Braided Hose	1				
32	33500-132-0	Center Pivot Lock Nut	1				
33	48400-133-0	3/8" ID Braided Hose x 38"	1				
34	48400-134-0	Fitting 1/4 npt to 3/8 Braided Hose	1				
A35*	A135CB-8	Center Block Assembly	1				
		* Includes the following ITEM NOs					
12		Center Block Bushings (available only in A35)	2				
14		Arm Pivot Pin Bushings (avail. only in A23 or A35)	4				
35		Center Block (available only in A35)	1				
40		Pivot Pin (avail. only in A23 or A35)	1				
40		Long Pivot Pin (avail. only in A23 or A35)	1				
49		Precision Eye Bolt (available only in A35)	1				
36	33500-136-0	Base Pivot Pin Jam Nut	1				
37	38400-137-0	Fitting - 1/8 npt to 1/4 Tube	1				
37	48400-137-0	Fitting - 1/4 npt to 1/4 Tube	1				
A38*	A138TB-SET	Thrust Bearing Assembly - Center -Pair	1				
		* Includes the following ITEM NOs					
38		Thrust Bearings	2				
39		Thrust Washers	4				
41	33500-141-0	Arm Pivot Nuts	4				
42	46200-142-0	Heavy Duty Lower Parallel Arm	2				
43	33500-143-0	Clevis Bracket Mtg Screws	2				
A44*	A144UA-8	Upper Parallel Arm Assembly	1				
		* Includes the following ITEM NOs					
13		Upper Arm Cyl. Bushings (available in A44 only)	2				
44		H D Upper Parallel Arm (available in A44 only)	2				
45	38400-145-0	Fitting - 1/4 npt short street elbow	1				
46	38400-146-0	Fitting - 3/8 npt street elbow	1				
47	38400-147-0	Hardened 1/4 npt Hex Nipple	1				
48	46200-148-0	Large Rod Eye	1				
50	38400-150-0	1/4" OD polyurethane tube -Red 8" long	1				
54	43500-154-0	Large Jack-knife Stop	1				
A58*	A158TB	Thrust Bearing Assembly - Bottom Rear	1				
		* Includes the following ITEM NOs					
58		Thrust bearing (available in A58 only)	1				
59		Thrust washers (available in A58 only)	2				

For PA815-OM

	Substitute		
A23	A123RB-8-OM	Rear Block Assembly- Overhead Mount	1
	For		
A23	A123RB-8	Rear Block Assembly	

Ergonomic Tool Arms, LLC
3 YEAR LIMITED WARRANTY - within USA

All metal components including bearings and shafts of Ergonomic Tool Arms and ETA accessories are warranted to the original purchaser and their assigns against manufacturing defects and excessive wear under normal industrial use for a period of 3 years from date of purchase. Items specifically covered below are not covered by this 3 year warranty.

1 Year Warranty on Pneumatic Components. ETA warranties all pneumatic parts against defects in material or workmanship for 1 year from date of purchase. Due to the possibility, beyond the control of ETA, of chemical attack by certain airborne compressor oil additives, this 1 Year Warranty does not apply to soft (non-metal) parts that are definitely affected by chemicals within air system. This includes seals within regulators, cylinders & valves, all air lines and fittings. Some of these parts may be covered by warranties from the companies who manufacture standard pneumatic components for ETA. Contact ETA for more information. When not covered by warranty, replacement air system parts and hoses are available for sale from ETA through your Industrial Distributor.

1 Year Warranty by ARO for their 50 Series Power Unit used on ETA Tapping Systems –. See Owner's Manual for **PAT806-X models** for preventive maintenance, repair and warranty information on this ARO/Ingersoll-Rand tapping motor.

General Info on ETA Warranties Above.

Uses other than that intended and stated by the ETA, any abuse, damage from natural disasters, or modification to the form or function of the product, will void this warranty. Intentional tampering with spec and serial number tag on the forearm may also invalidate this warranty.

ETA Products are intended for use with filtered compressed air only, at 125 psi maximum. Use at higher pressures or with other gases or using hydraulic fluids with this product is a violation of this warranty and may pose a safety or health hazard. If in-line, air-lubrication is used, it must be in accordance with the Owner's Manual applicable to the ETA Model in question or this warranty will be voided.

ETA Products are intended for use in climate controlled indoor environments, not subject to outdoor elements. Rust, corrosion or weathering due to exposure to uncontrolled climate conditions is not warranted.

Choice to repair or replace parts that are covered by warranty claims is at the discretion of Ergonomic Tool Arms, LLC. All repairs or replacements are warranted for the remainder of the original warranty period only. All other repairs not covered by this warranty, will be completed after a written estimate of time and materials is agreed to by your distributor. Whenever practical, replacement parts will be most current revision at the time of repair.

Contact ETA or the distributor you purchased ETA products from for Return Material Authorization Number (RMA #) before shipping back to ETA. Customer is responsible for shipping costs to ETA in Doylestown, PA. ETA will pay return freight of products repaired under warranty to customers within the continental United States. Customers outside continental United States may have to pay for additional freight and/or customs costs.

This warranty supersedes all prior warranties written, oral, express or implied. This warranty does not cover and Ergonomic Tool Arms, LLC will in no event be liable for any business interruptions, loss of profits, harm, injury, damage, personal injury, cost of delay or any special indirect, incidental or consequential losses, costs or damages. ETA's maximum liability is limited to the purchase price of the tool arm or tool arm accessory.

Note; Some states in the USA do not allow limitations on incidental or consequential damages, so these limitations may not apply to all customers. This warranty gives you specific legal rights. These rights vary from state to state.