

THREAD TAPPING SYSTEMS WITH QUICK CHANGE TAP HOLDER

Fast, accurate tapping of same or different size threads, on large or small parts at a much lower cost than a machine tool. Operator can thread parts while his CNC machine mills and drills the next parts. Great for threading sheet metal panels too.

Each ETA Tap Arm System Includes:

- PA806 Arm with ARO50 Air Tool Holder
- Ingersoll-Rand 50 Series Power Motor specially built for tapping.
- Bilz Size 1, Quick Change Tap Holder. Holder will accept Bilz, T.M. Smith, Collis, Universal, Lyndex and other Size 1 Tap Adapters. (Clutch type tap adapters are recommended)
Tap Adapters are not included with this system.

Air Requirements; filtered, lubricated air - 100 psi. @ 25 scfm

MODEL # **PAT806-4MC** includes **Automatic Mist Coolant System**. Each time the tap motor is actuated, the pneumatic logic system mists the tap or hole at adjusted time intervals until the motor stops.



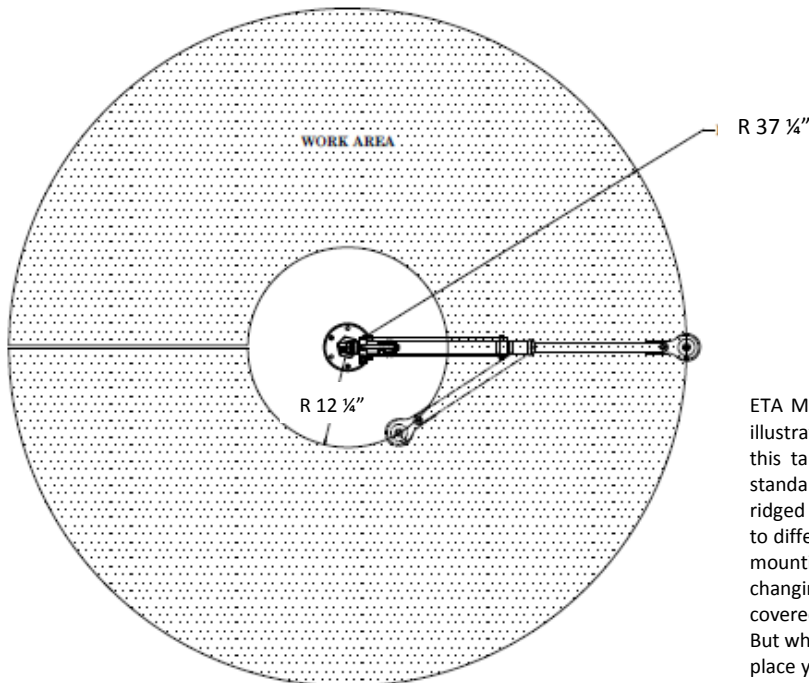

ETA MOUNTING SYSTEM. Maximum and minimum dimensions are illustrated to the left and are based on the pipe nipple included with this tap arm. Our tap arm base components are machined with standard 1-1/4" national pipe thread. This makes a completely ridged mounting post, while allowing you inexpensive adaptability to different work locations. If you need to adjust the reach from the mounting base of the arm to your work, it can be done simply by changing or adding to this 1-1/4" npt pipe. The amount of area covered vertically and horizontally is fixed by the arm's pivot points. But where that coverage area begins and ends, in relationship to the place you want to anchor the mounting base, can be easily changed with pieces of pipe and fittings, like elbows and/or tees. See MOUNTING IDEAS on our website, www.taparms.com.

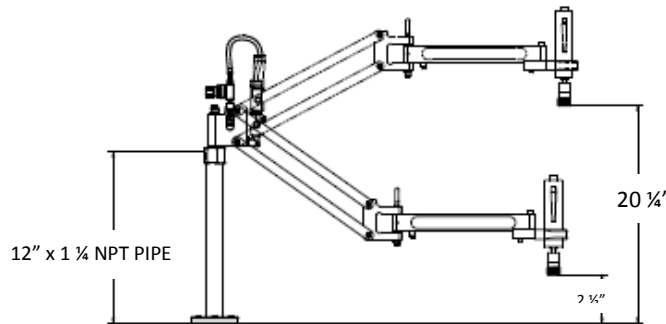

MODEL SELECTION

MODEL #	DESCRIPTION	CAPACITY	MAX TORQUE	
			in-lbs	Nm
PAT806-4	Arm with 400 RPM Tap Motor	vertical thread tapping up to 9/16" in steel	276	31
PAT806-6	Arm with 600 RPM Tap Motor	vertical thread tapping up to 3/8" in steel	168	19
PAT806-4MC	Arm with 400 RPM Tap Motor and Auto Mist Coolant System	vertical thread tapping up to 9/16" with mist coolant	276	31
PAT806-6MC	Arm with 600 RPM Tap Motor and Auto Mist Coolant System	vertical thread tapping up to 3/8" with mist coolant	168	19



Doylestown, PA - USA 855-TOOL ARM (855-866-5276)
 Email; etainfo@toolarms.com

ETA tool arms and tap arms available through industrial distributors.

We also make arms for FASTENING and DRILLING applications.
 Get more information at www.toolarms.com